

Suspensions air Série Bleu OBD-E (14 ton)

OBD-E

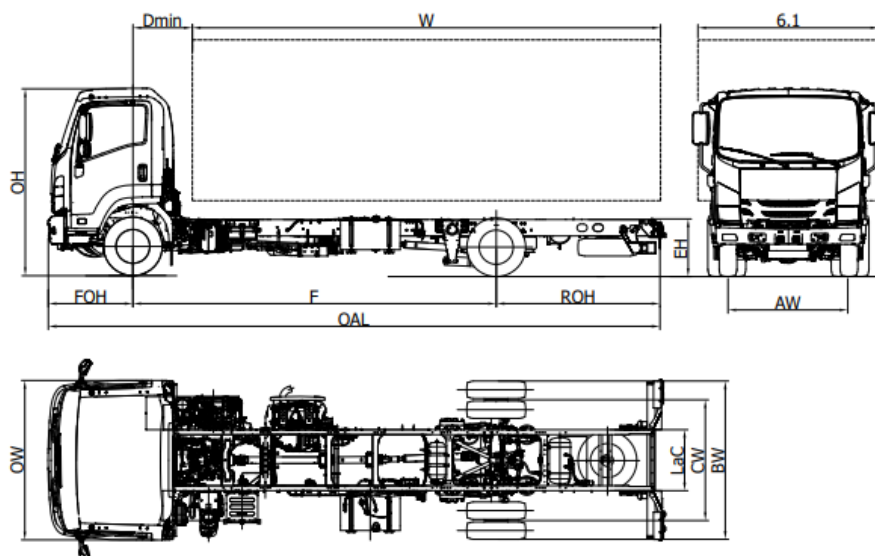

F 14		F 14 J	F 14 L	F 14 N	F 14 Q
Wheelbase	F	3790	4360	4990	5320
Overall length	OAL	6610	7480	8380	8680
Body length min. ⁽¹⁾	W	4725	5595	6495	6795
Body length Max. ⁽¹⁾	W	5025	5895	6795	7095
Rear overhang	ROH	1645	1945	2215	2185
Chassis height	EH	785			
Overall height	OH	2600	2595	2595	2595
Rear axle width	BW	2225			
Cab width ⁽²⁾	OW	2195			
Body width ⁽³⁾	6,1	2535			
Front axle to back of cab	D min	710			
Front overhang	FOH	1175			
Frame internal size	LaC	840			
Front track	AW	1800			
Rear track	CW	1670			
Turning diameter (m) ⁽⁴⁾	Dia	13,7	15,5	17,5	18,6
WEIGHT (kg)					
Unladen weight ⁽⁵⁾		4270	4330	4400	4410
Unladen weight front axle		2685/1585	2735/1595	2775/1625	2790/1990
Gross Vehicle Weight (GVW)		14000			
Front/rear total weight		5000 / 9000			
Max trailer weight braked/ Max trailer weight unbraked		3500 / 750			

1. The length of the body refers to a uniformly loaded vehicle, up to the maximum capacity on each axle (dimensions declared in C.O.C. with no chassis modifications).
2. Excluding turn signal and side mirrors
3. Possible widths with optional mirror brackets 2220/2286 -2286/2406 -2406/2500 - 2500/2535
4. Curb to curb turning diameter
5. The Unladen weight include spare wheel, full fuel tank and driver, optional excluded. NEES II + 25 kg.

PROVISIONAL VERSION: All data must be confirmed by the type approval certificate.

F 14 - Wheelbase (mm) J 3790 - L 4360 - N 4990 - Q 5320

JUNE 2023

Equipment	NEES 2 + HSA	
Standard features		
<ul style="list-style-type: none"> • EGR - DPD - SCR • MID display • Air conditioning • Speed limiter (90km/h) • Engine exhaust brake • Power operated windows • Air spring seat 	<ul style="list-style-type: none"> • Seat belt buzzer • Cab overturning safety • Side mirrors heated and electric • Steering adjustable (tilting and height) • Radio DAB+, USB, Bluetooth • Immobilizer • variable SLD 	<ul style="list-style-type: none"> • Head lamps control levelling • Central locking with remote control • Cruise control • Day-time running lights • Front led lights • Fog lamps Fr and Rr
Engine	<p>ISUZU 4HK1E6H 4 cylinders. common rail direct-injection intercooler with Twin-Turbocharger, additional injector on exhaust pipe. DISPLACEMENT 5193 cm³ POWER 177kW (240 hp) 2400 rpm TORQUE 765 Nm - 1600 rpm EMISSIONS REGULATIONS EURO VI OBD-E.</p>	
Safety systems	ABS ESC (Electronic Stability Control) with ASR LDWS AEBS SRS Driver Airbag	
Tank	140 L	16 L Ad-Blue®
Gearbox and Final drive ratio	6 gear MZW6P - 6.615 - 4.095 - 2.358 - 1.531 - 1.000 - 0.722; Reverse 6.615; Final gear ratio 5.571 (39/7)	
Transmission control	Manual	NEES 2 + Kick down
Dimensions of the chassis	Width 60 mm, Height 225 mm, Thickness 6 mm	
Number of seats	3	
Tires	Front: 265/70 R19,5C simple. Rear 265/70 R19,5C dual	
Brakes	Front and rear drum brakes. To EEC standards with 4-channel ABS, Full Air pneumatic system with two independent circuits and EBS (Brake by wire) electronic control. Engine brake on the exhaust. Pneumatic parking brake on the rear axle.	
Suspensions	Front: Multi taper leaf spring.Rear: 4-bag Air Suspension with height control.Front and rear stabilizer shaft.	
Electric system	2 battery 110 A - System 24V - Generator 90A	